

SHERPAK™ GO!15

INSTRUCTIONS



1. Clean the top of your vehicle

Dirt trapped under the Sherpak GO!15 could scratch the paint on your vehicle's roof.

2. Optional Sherpak Super Mat

Place the optional Sherpak Super Mat on the roof of your vehicle. The Super Mat adds a little padding and helps to protect the roof of your vehicle.

3. Positioning the Sherpak GO!15

Place your GO!15 on the roof of your vehicle with the zipper opening facing the rear of the vehicle.

4. Loading the Sherpak GO!15

Place items in the GO!15 carefully and distribute the weight evenly. Take care to not drop or throw items in as this could damage the vehicle's roof.

5. Zip the Sherpak GO!15

Close your GO!15 making sure the zipper flap is covering the zipper to ensure a weatherproof seal.

6. Secure the Sherpak GO!15

The GO!15 will attach to cars with or without racks. Attach your GO!15 using one of the three methods (A, B, or C).

7. Compress the Sherpak GO!15

The side mounted compression straps should be firmly secured over the top of your GO!15 before driving. The compression straps hold cargo in place and reduce noise caused by loose vinyl. Tuck any extra fabric under the compression straps to secure it in place.

Our Sherpak Super Mat (not included) helps protect your car top. Go to seattlesportsco.com to check them out.

NON-ZIPPERED
SIDE FRONT

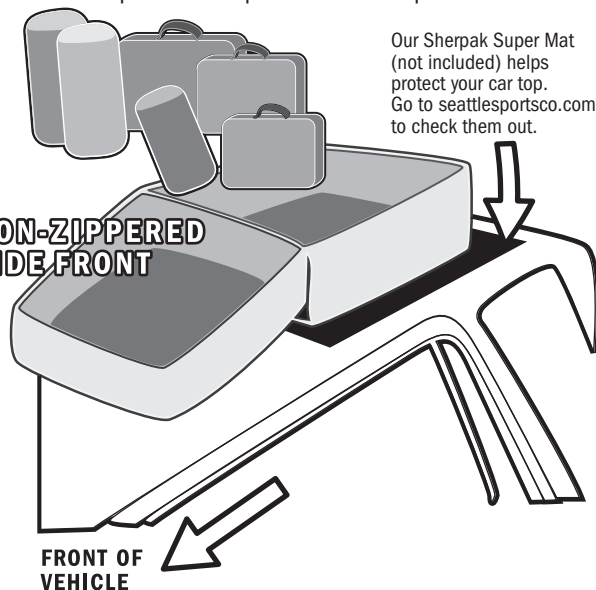

Three - in - One UNIVERSAL MOUNT

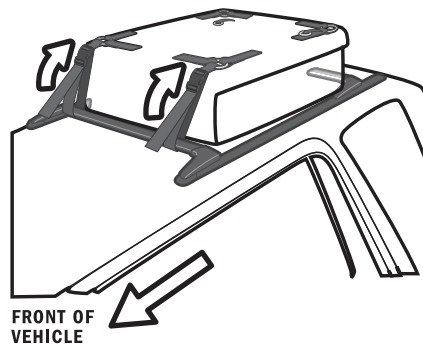
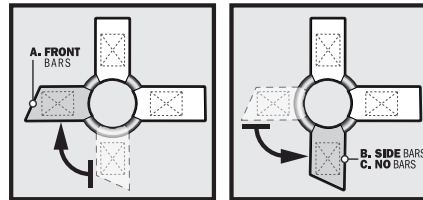

A. Front Bars

Rotate the 2 inch straps toward the front of your vehicle. Loop the straps under your rack bars and snap the buckles closed. Tighten the straps until they fit snugly; don't cinch so tight that you damage your roof or rack bars. Tuck the excess straps into the attached strap keeper. Repeat with rear straps (toward rear of vehicle).

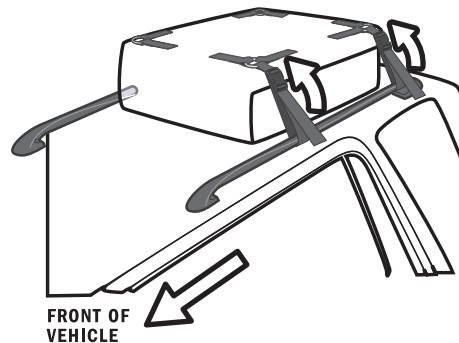

B. Side Bars

Rotate the 2 inch straps toward the sides of your vehicle. Loop the straps under your rack bars and snap the buckles closed. Tighten the straps until they fit snugly; don't cinch so tight that you damage your roof or rack bars. Tuck the excess straps into the attached strap keeper.

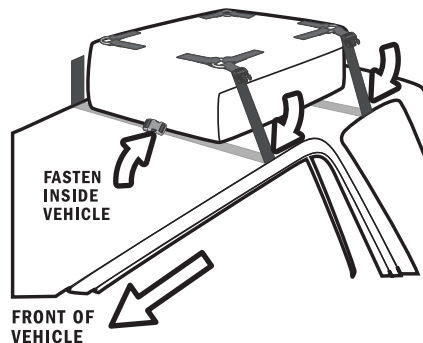

C. No Bars

Rotate the 2 inch straps toward the sides of your vehicle. Open the doors and thread the straps through the interior of the vehicle and fasten together. Tighten the straps until they fit snugly; don't cinch so tight that you damage your roof.

Compression Straps

The side-mounted compression straps should be firmly secured over the top of the Sherpak GO!15 before driving. If you experience excessive noise while driving, stop and tuck in any extra material and cinch the compression straps.

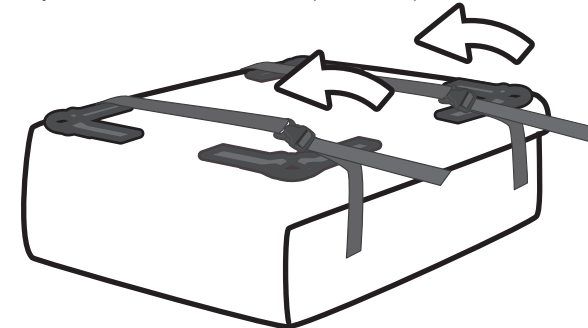

Careful now!

At every stop check your straps and buckles before driving.

Do not load your Sherpak GO!15 on the ground, then try to lift it to your roof. Lifting heavy objects may cause personal injury. You may damage the roof of your car. Finally, excessive pressure on any sewn point of the GO!15 may cause irreparable damage.

Maintenance

The Sherpak GO!15 is made from heavy-duty coated vinyl which can easily be washed with soap and water. If you want to maximize its lifespan, clean it with vinyl conditioner following the product instructions.

Keep sharp objects away from the webbing. When the GO!15 is not in use, fold it up with the webbing and buckles in the middle to protect them.

WARNING Contents may shift during travel. Do not attempt to lift a fully loaded Sherpak onto or off a vehicle. Always secure your Sherpak each time before driving. If you hear excessive flapping noise immediately pull over and check to make sure the Sherpak is firmly secured. Be extremely care to make sure sharp or heavy objects are well-padded within the Sherpak. If there is any question, put these objects inside your vehicle.

WARNING Due to the fact that Seattle Sports does not have control over how this device is used, Seattle Sports disclaims any and all liability for damage or injury that might occur as a result of the improper use of this product.

WARRANTY Seattle Sports products are guaranteed for materials and workmanship for one year. Normal wear and tear or damage from misuse, accident, or alterations are not covered. Use of this product in a professional setting is not covered. Seattle Sports assume no liability for incidental damages or injuries resulting from the use or misuse of this product. You may have additional warranties or limitations outlined in product packaging. Thank you for purchasing our products. Please contact us with any questions or concerns about our products. Seattle Sports Company, 3217 W. Smith St #1, Seattle WA 98199. Made in China. Copyright 2013